

MMT-1616 (GRAPHITE)

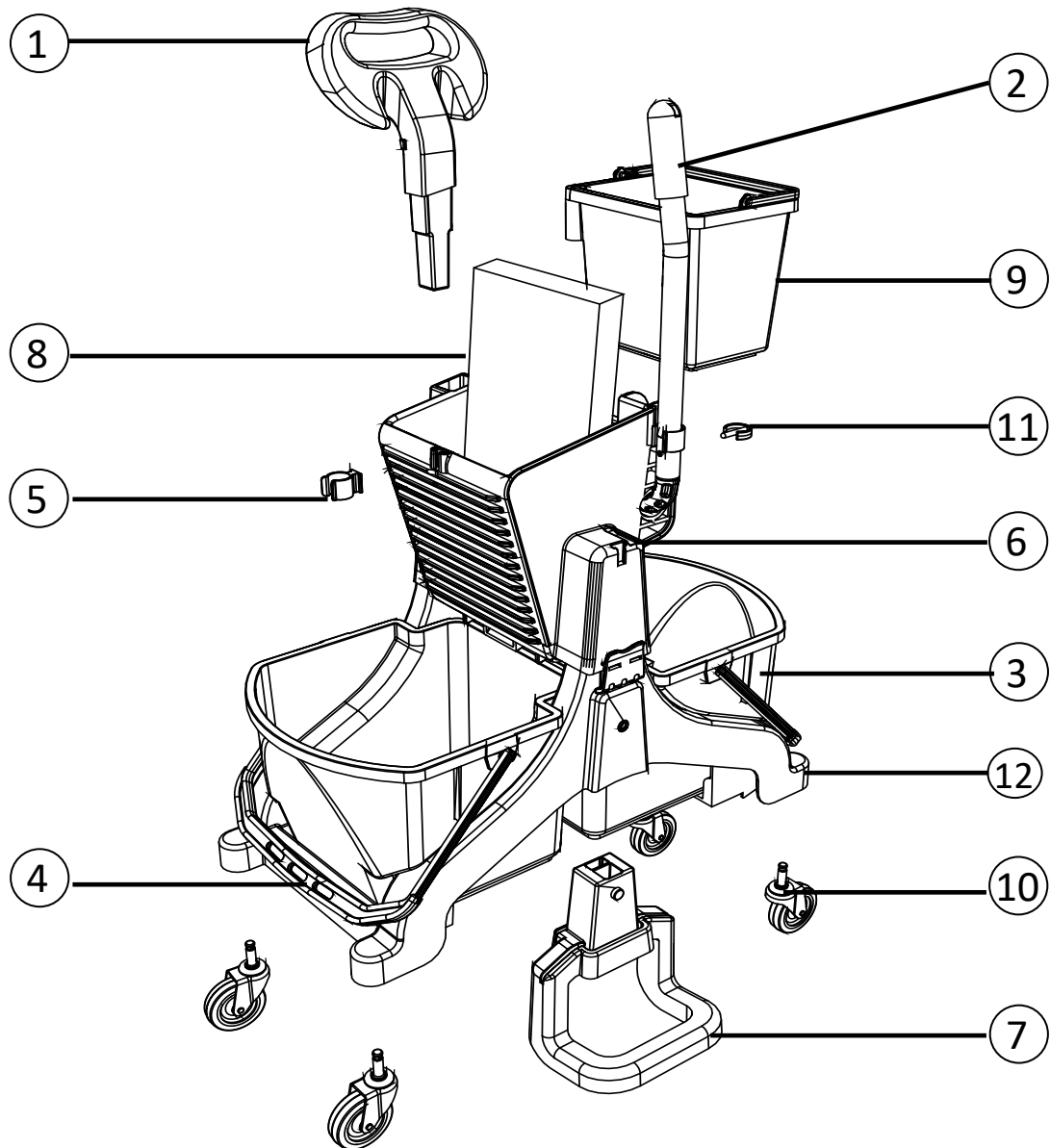

ITEM	PART	DESCRIPTION	QTY
1	902090	MIDMOP HANDLE COMPLETE (GRAPHITE)***OPTIONAL EXTRA	1
2	902094	PRESS HANDLE	1
3	905733	16 LTR PAIL RED HANDLE	1
4	905734	16 LTR PAIL BLUE HANDLE	1
5	629874	22MM MIDMOP CLAMP	1
6	906471	PRESS ASSEMBLY WITHOUT FOAM (GRAPHITE)	1
7	902092	FLAT MOP STAND (GRAPHITE)***OPTIONAL EXTRA	1
8	629881	FOAM PRESSURE PAD***OPTIONAL EXTRA	1
8	905225	5LTR SWING PAIL RED HANDLE***OPTIONAL EXTRA	1
10	629882	75 MM CASTORS	4
11	206394	UNIVERSAL CLIP	1
12	902095	MID MOP BASE (GRAPHITE)	1

